

MacARTHUR
FUNDAMENTAL INTERMEDIATE SCHOOL

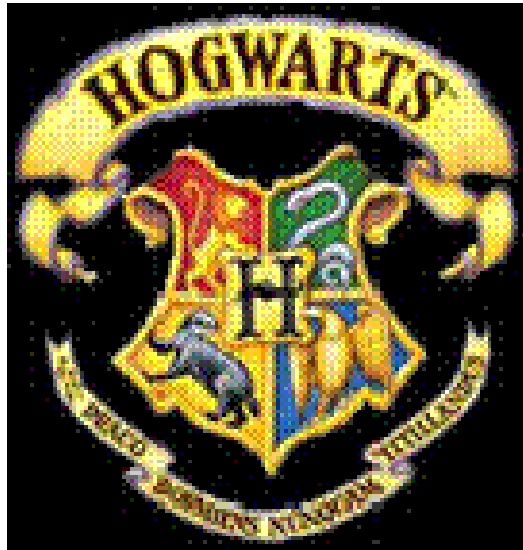

When: Thursday, May 27th



School of Opticks
& Astronomy

Telescope
Challenge



OSA[®]

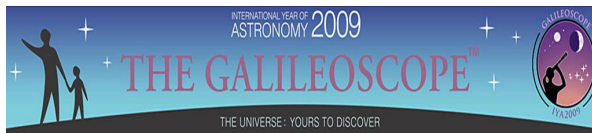

OPTICAL SOCIETY
OF SOUTHERN CALIFORNIA
www.oss.org



Where are optics in everyday life?



Bar Code Scanners
In retail shopping.



Televisions



Medical Lasers



Computer
Scanners



CD / DVD
Recorders
Players



Fiber Optics
Telecommunications



Cameras



Projectors

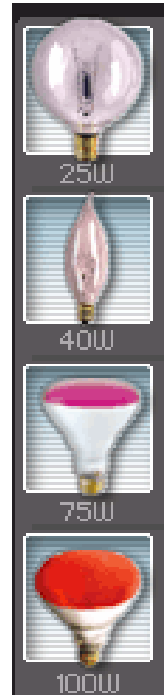

Light Bulbs

What is Light??

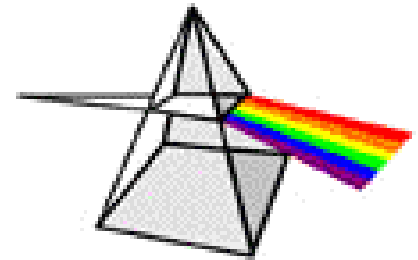

The Visible Light Spectrum



Red
Long λ
Low f

Violet
Short λ
High f

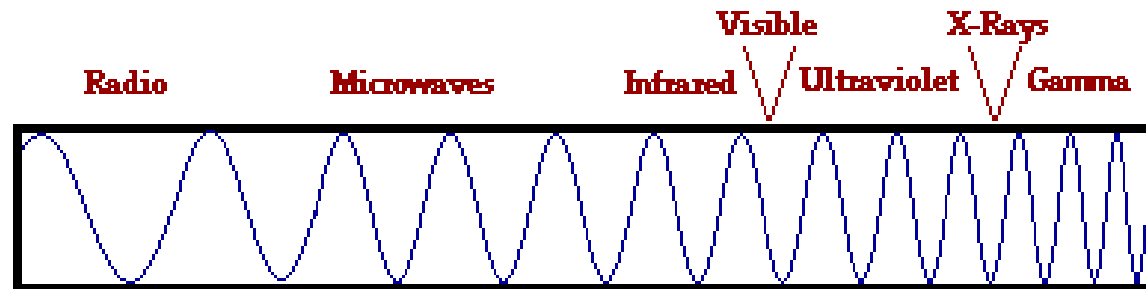

Long λ
Low f

Short λ
High f

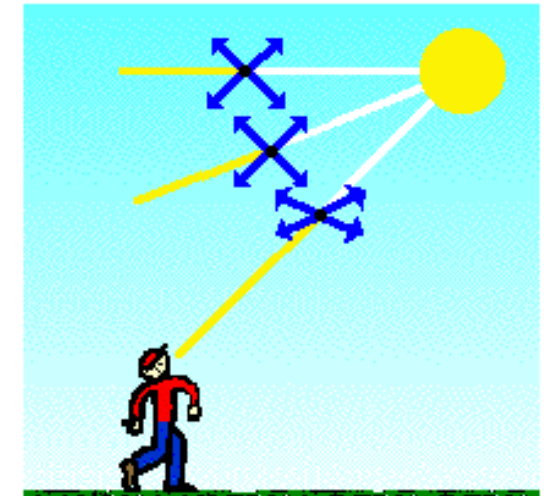

The yellow appearance of the noon-day sun is due to the scattering of the higher frequencies of sunlight.

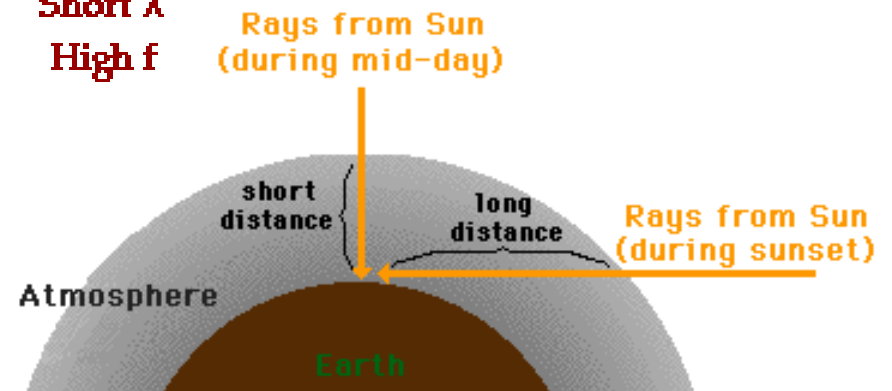

Learn Optics in High School

Study Optics in College

Use Optics in your career

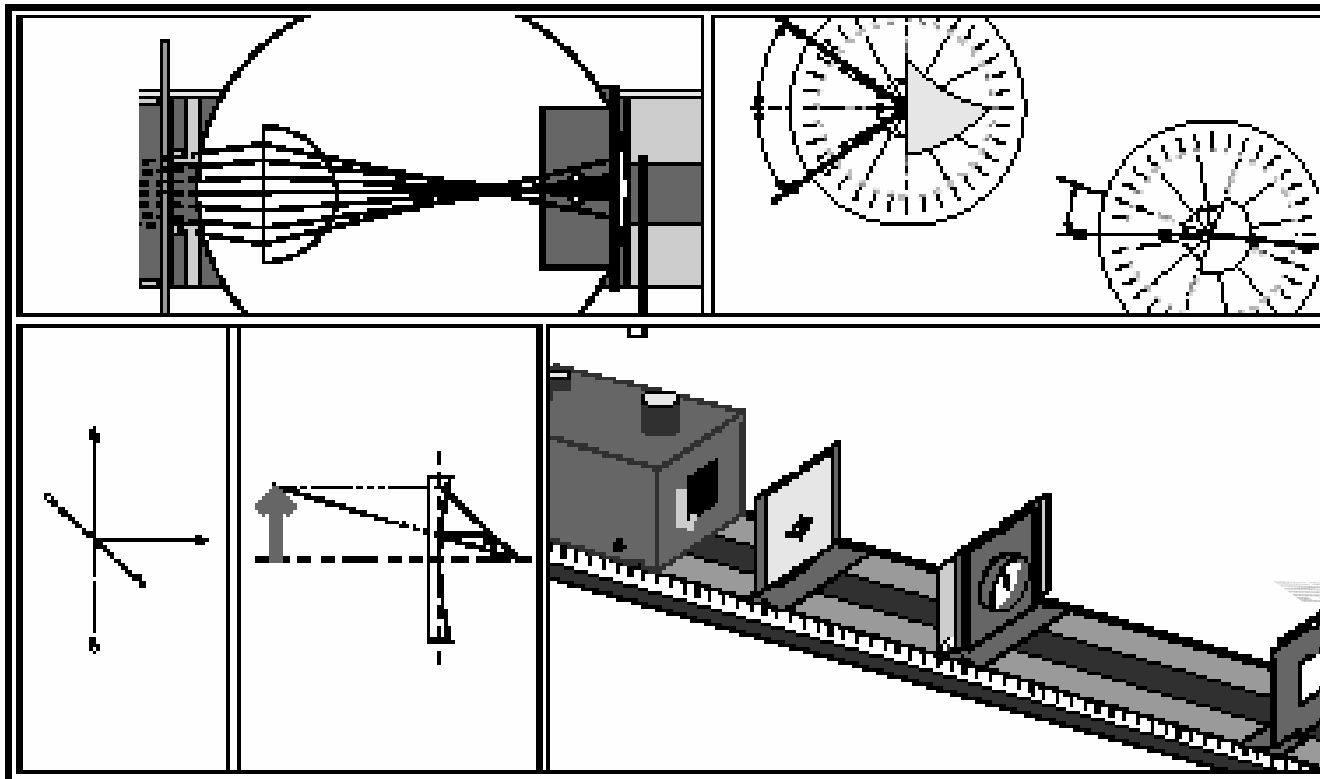

Optics is FUN!!!

What's the difference between these optical instruments??



Nikon Binoculars



Binolux Binoculars



Selsi Monocular



Celestron Finder scope (telescope)

EQUIPMENT NEEDED:

-Optics Bench

-150 mm Focal Length Convex Lens

-75 mm Focal Length Convex Lens

-Component Holders (2)

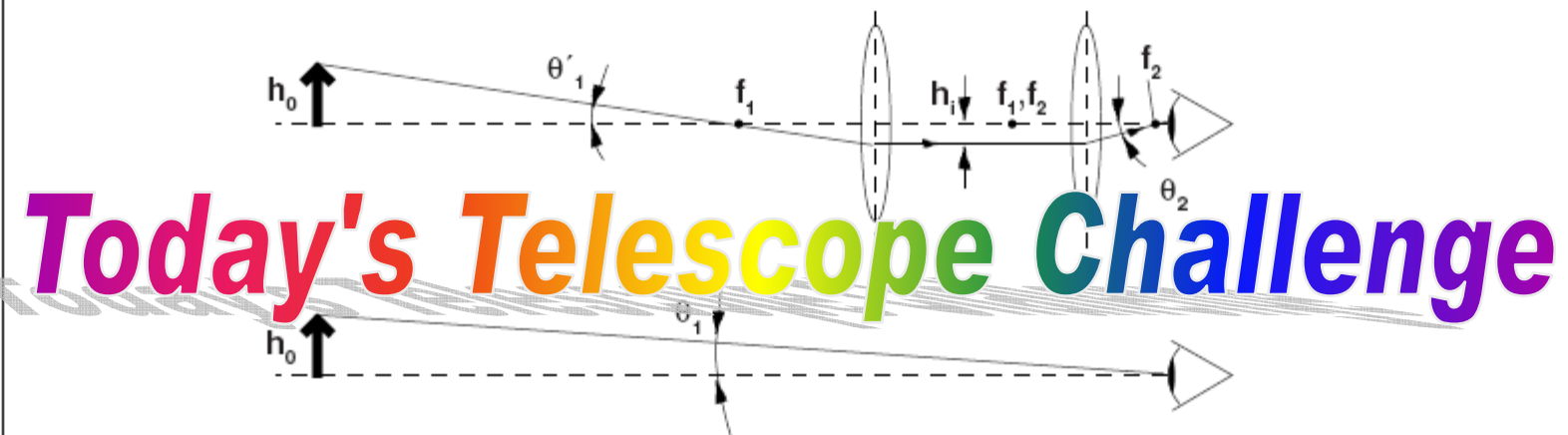
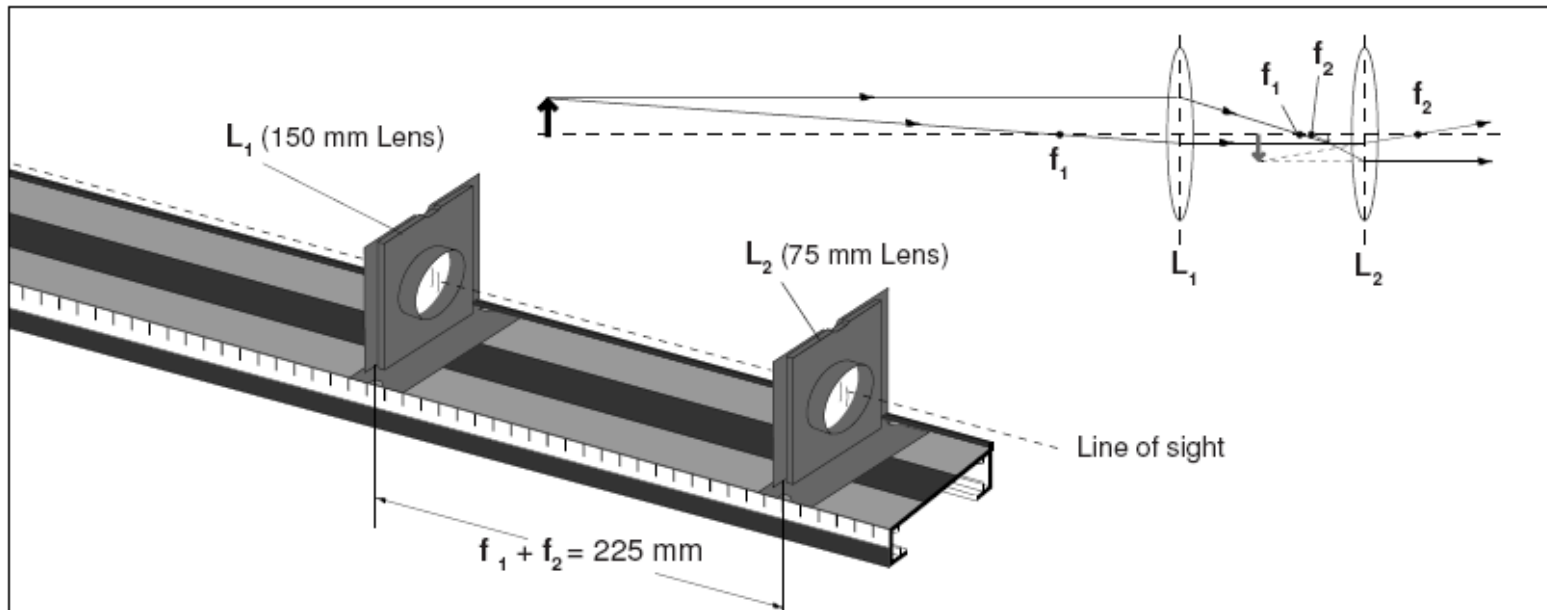

Figure 21.2 Telescope Magnification

Exhibit Description:

The Optics Institute of Southern California offers high school students information and opportunities to discover the Wonderful World of Optics. Optics and the high tech version "Photonics" is way beyond eyeglasses. Optics and Photonics are everywhere in your daily lives and in the most high tech places like out in space, corporate, government and university research labs and at the bottom of the oceans (and everywhere in-between!!).

Questions for Students to think about:

1. How many 'things' can you name in your daily life that uses optics or 'photonics' as the fundamental component to make it work?

Light bulbs, TVs, DVD & CD players, laser printers, cameras, projectors, liquid crystal displays (flat LCD monitors, cell phone, watches, microwave ovens readouts), fiber optics connecting telephones and cable TVs, medical & dental X-Rays, mirrors & windows in home, building and cars, street lights and reflectors, microscopes and telescopes and oh yes and eyeglasses, contact lenses, sunglasses and your eyes!!

2. What is 'Light'? - *Here we are not asking what is a light bulb, but what is the actual light? Think about the word 'Lightwave', then sound wave, then water wave. There are some conceptual and mathematical similarities. But the fundamental concepts are quite different. What is "it" that goes into our eyes and allows a signal to register in our brains that indicates we have 'seen' something?*
3. What good is learning about optics & photonics? *Since optics are everywhere, learning about them now can help focus your attention on science as a career choice. Knowing the fundamental concepts of optics and photonics can be lots of fun (come see our OPTRICKS) and can help you in many scientific adventures in many different fields.*

What's a Fresnel Lens Anyway?

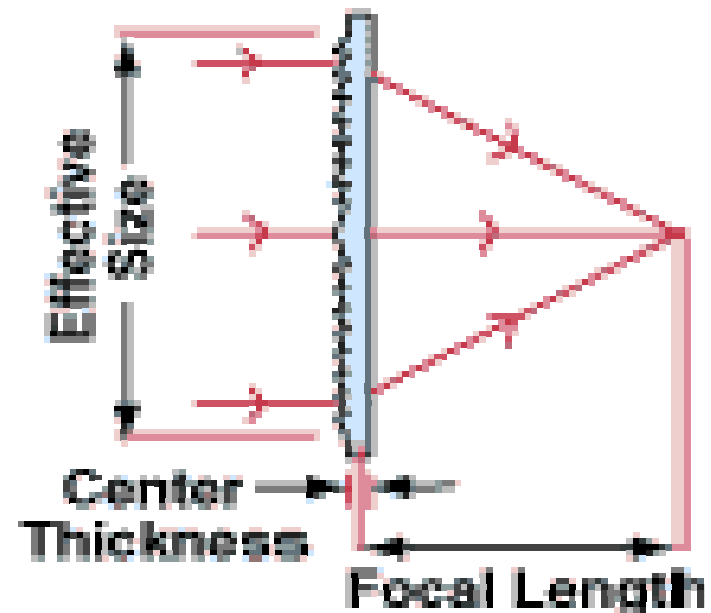
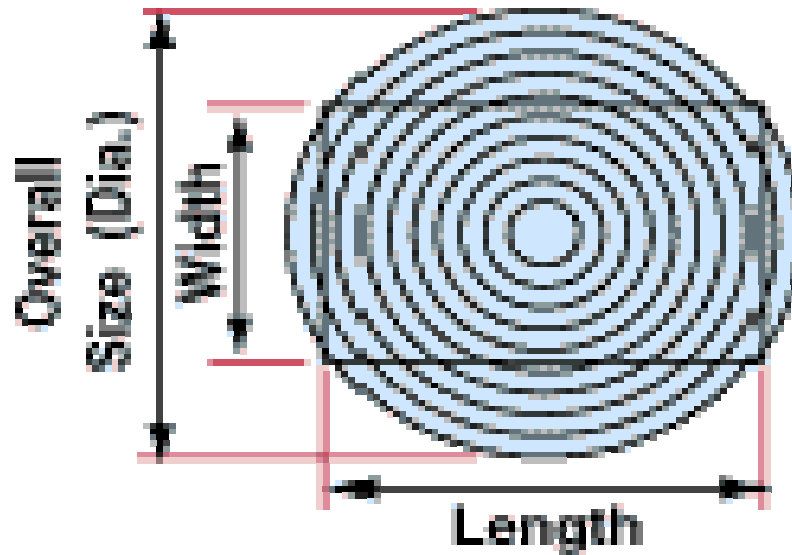

Lenses and Magic Dots

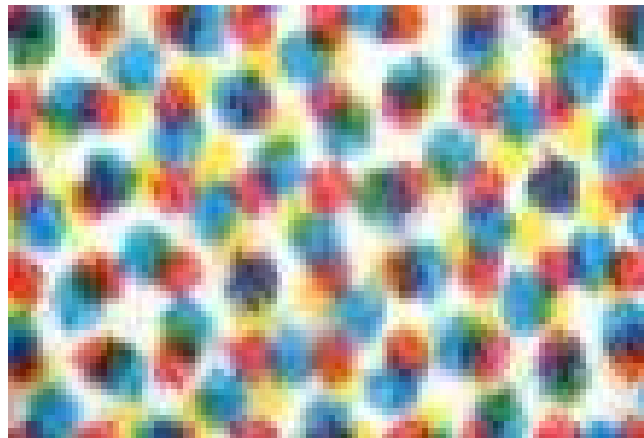

Magic Stripes

Polarization of Light

- Where do the colors come from?
- Make your own polariscope and find the stripes in the plastic and glass materials.
- Geologists, identify minerals with polarized light microscopes.
- Civil engineers examine stresses inside structures with transparent models and a polariscope.



The Electromagnetic Spectrum

Size of waves

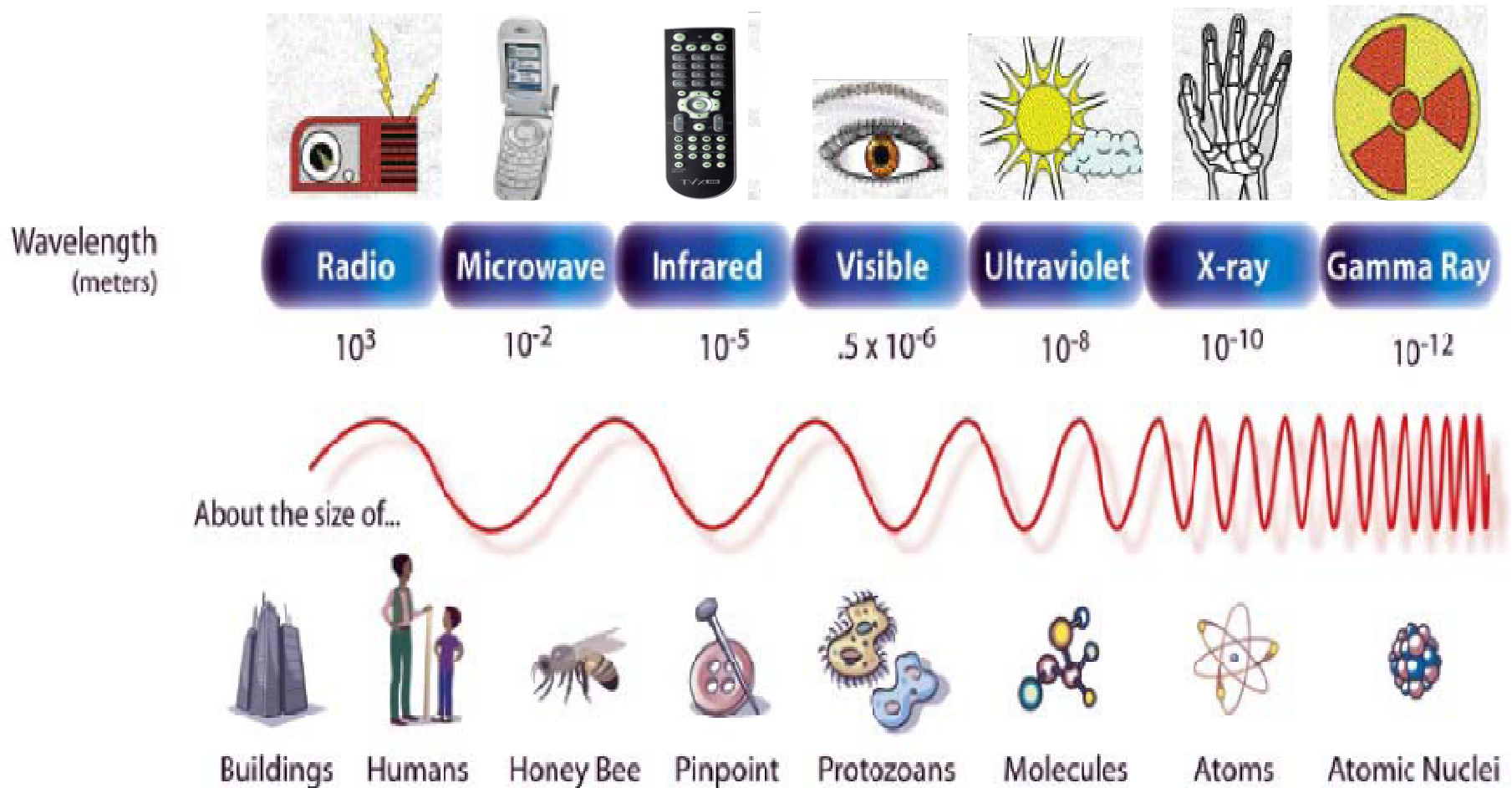

Color = Wavelength

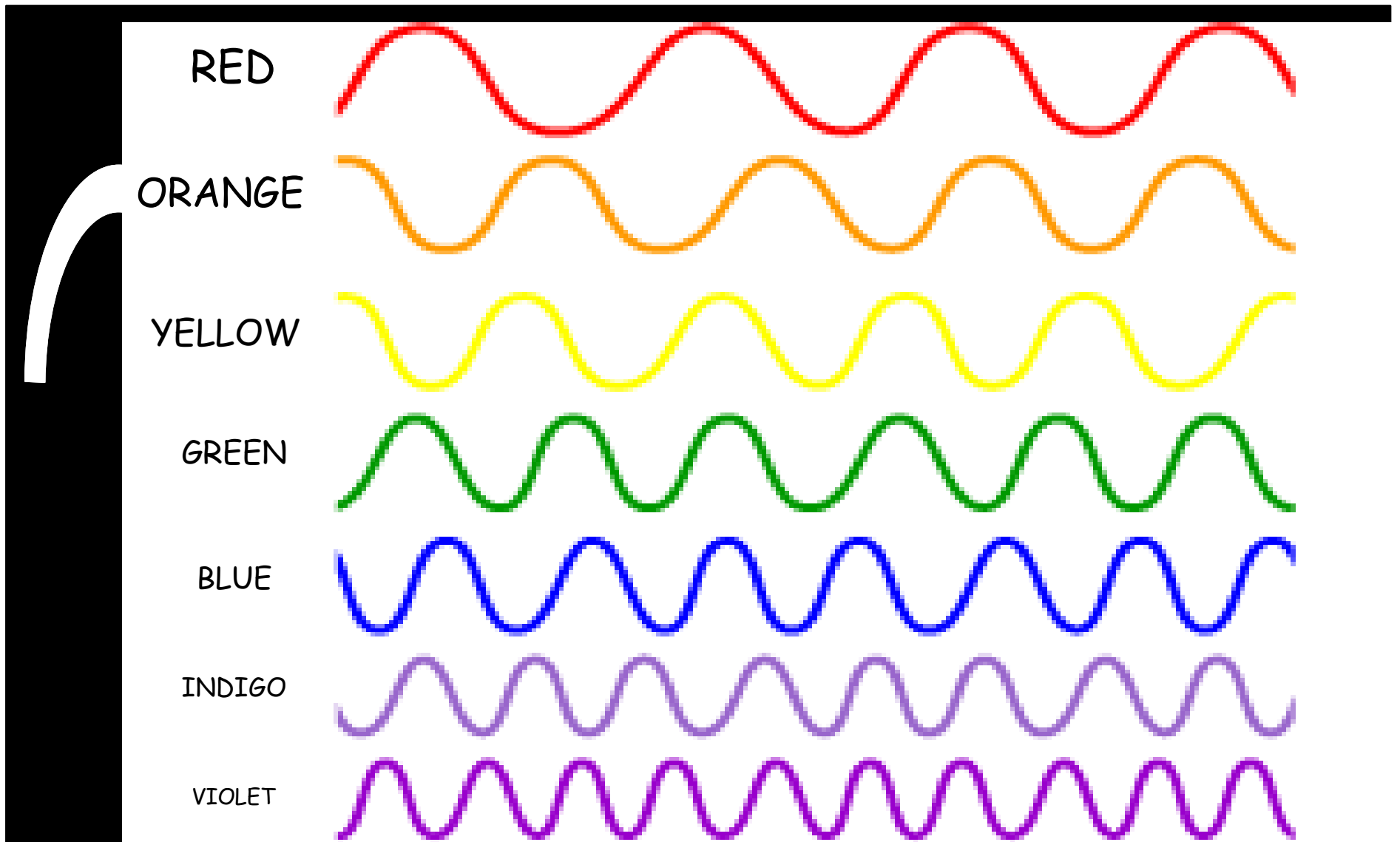

Diffractation - Separate the waves

- Since light is a wave, it can be made out of a bunch of waves
- You can separate the waves to see the different colors.

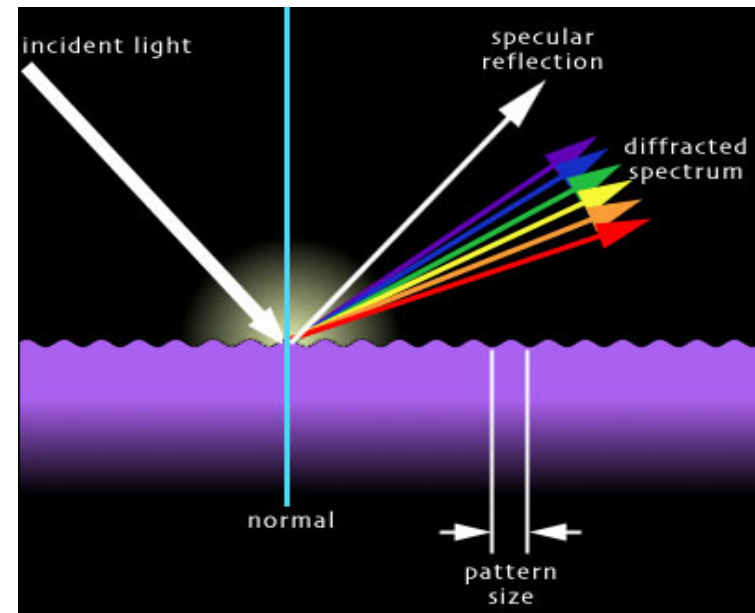

Rainbow Peepholes®

Diffraction Gratings

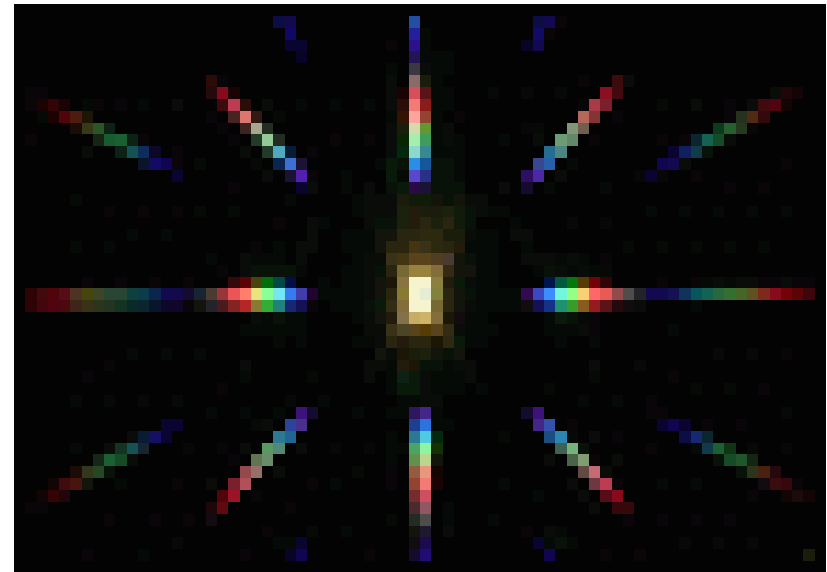

Rainbow Peephole[®]

Diffraction Gratings

- Light is “redirected” in passing through the plastic peephole to the eye.
- Where do the colors come from?
- Do you see a regular pattern?
- Identify the colors. Are they the same in each spot?
- Does the pattern change if the light is close or far from the peephole? How?
- Do you see colors from the room lights?
- The regular array of bumps on the plastic peephole's surface allows us to see the color in white light through “diffraction.”

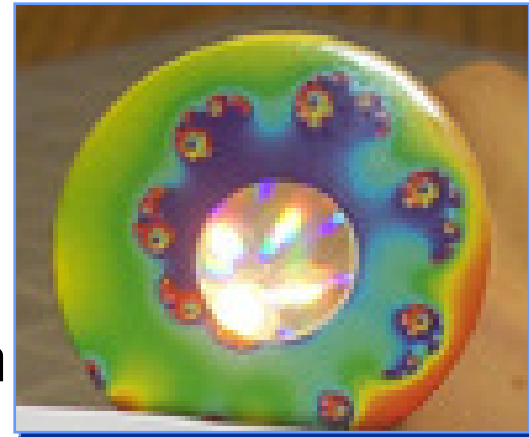

NEON Type Lamps

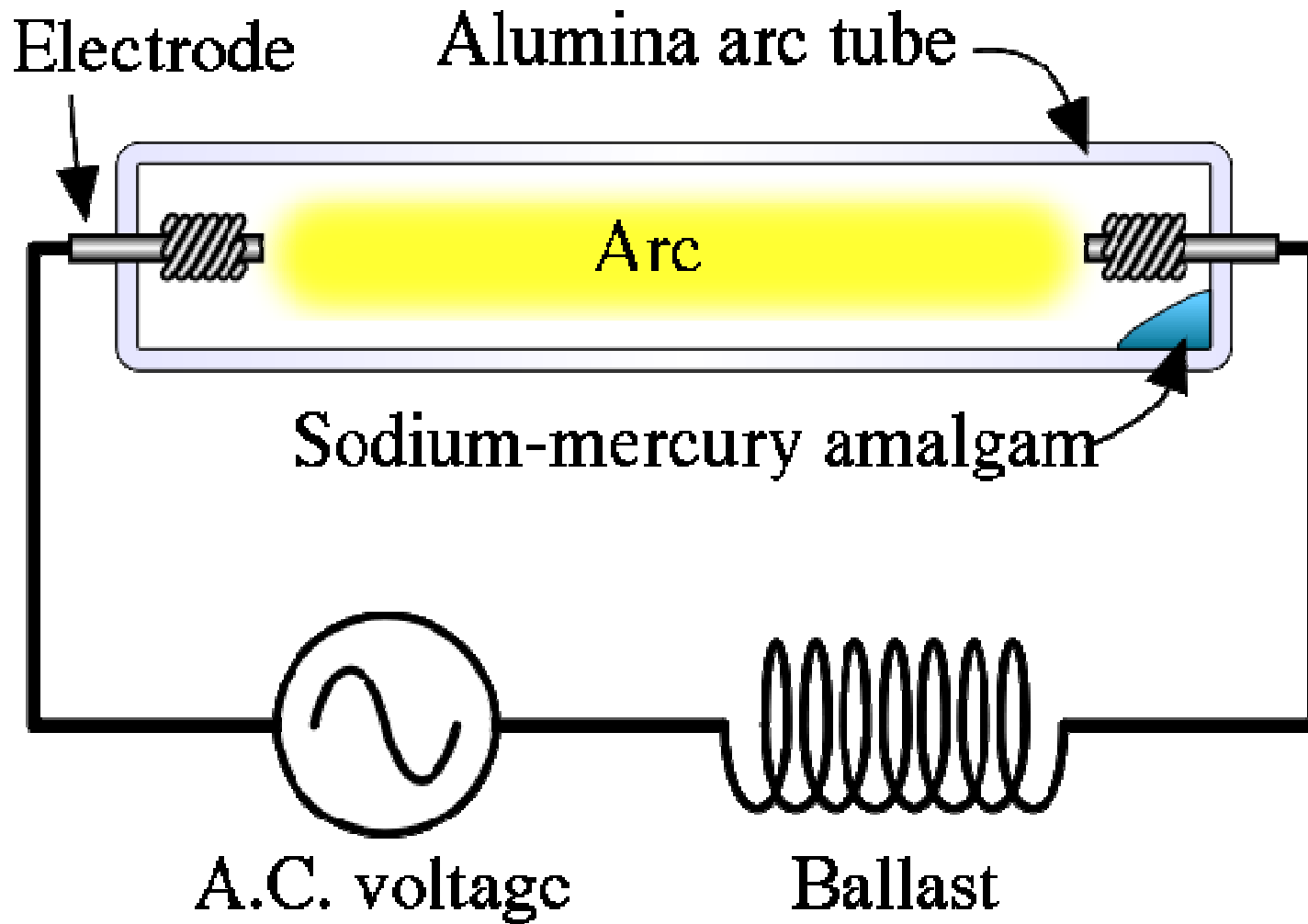

We can know what is in the light source by understanding the spectrum.

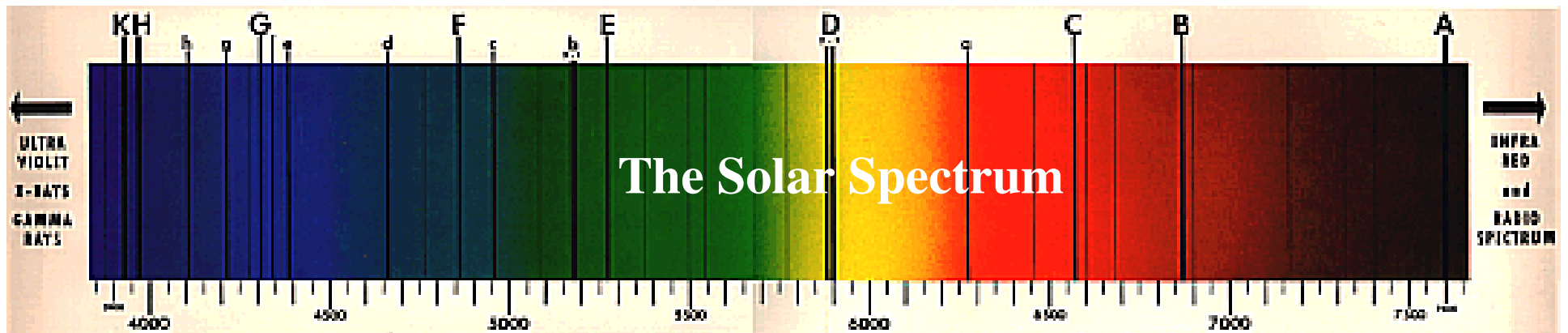

UV
X-Ray
Cosmic

Visible

IR
Radio



Magic Patch

(temperature data

vs. color)

- Place the patch on your wrist and perform the “vampire test.”
- The “*Magic Patch*” changes color with the heat from your body. The “living dead” give off no heat!
- Where do the colors come from?
- Does anyone see a vein or artery?
- This is an example of “selective reflection” by liquid crystals, painted onto the black paper.
- Liquid crystal are “ordered,” just like the students across the page.
- Scientists use liquid crystals to build displays for watches and computer games.

